

Contents of Kit

The PTAP2 Controller Kit contains two DIP-14 devices:

- 1 (One) Microcontroller (MCU). It is labeled “Atmel ATtiny84”.
- 1 (One) Digital potentiometer. It is labeled “MCP42050”.

The MCU comes pre-calibrated for internal timing accuracy and for the paired digital pots.

Adding the PTAP2 To An Existing Pedal

Adding the PTAP2 controller to an existing pedal is fairly simple and can be implemented on a board only slightly larger than the two DIP-14 chips. An example schematic complete with power regulation and associated passives is shown on the next page.

1. Power & ground are connected via B1. A 9V battery in the schematic represents this, but higher voltages will work just fine (up to 33V with the 78L05). It is recommended that a separate 78L05 is used for this board – sharing the one that is powering the PT2399s can allow the MCU to introduce noise.
 2. A 10k resistor is connected from the MCU's reset pin (4) to 5V.
 3. The existing delay pots are disconnected from the delay host board and connected to the MCU as shown with R1 and R2. Typical values are 50k but any value of R1 & R2 will work as long as they are linear.
 4. A normally-open momentary footswitch is connected as S1. The Carling 110-PM-OFF at Smallbear works well. The pull-up to this line is internal to the MCU so an external one is not required. The MCU also performs debouncing for the switch. However if your particular switch is still causing multiple “taps” per press a small decoupling capacitor can help. (The internal pull-up resistors are anywhere from 20k to 50k if you are trying to select a cap based on τ .)
 5. A SPST (or SPDT with one leg disconnected) switch is connected as S2. This switch should ground pin 3 of the MCU when the pedal is in Serial Mode and leave it floating when in Parallel Mode. (If your delay has a 3PDT switch already in place, such as with the BYOC Ping Pong pedal, it can be replaced with a 4PDT so you'll only have one switch to throw when changing modes.)
 6. The MCU communicates with the digital pot via 3 lines: SCK (clock), DO (data), and CS_N (chip select – active low.)
 7. The outputs of the digital pots are at U3 pins 5 (CCW), 6 (W), and 7 (CW), and pins 10 (CCW), 9 (W), and 8 (CW). These are connected to the VCO pins of the PT2399s and their series resistors* where the analog pots were originally.
 8. There are two LED pins available as well. Pin 12 of the MCU will go low when in Parallel Mode, and pin 11 will toggle in time to the tempo in Tempo Mode. If you choose to hook these up be sure to use an appropriate series resistor and connect the LED anodes to 5V, **not 9V**.
- NOTE: Both the timing calculations and current-limiting considerations are based on this series resistor being 1k, which is the standard value for most PT2399 kits. Other values will result in incorrect timing, and values lower than 1k will cause the digital pot to exceed its maximum pin current.

Example Schematic

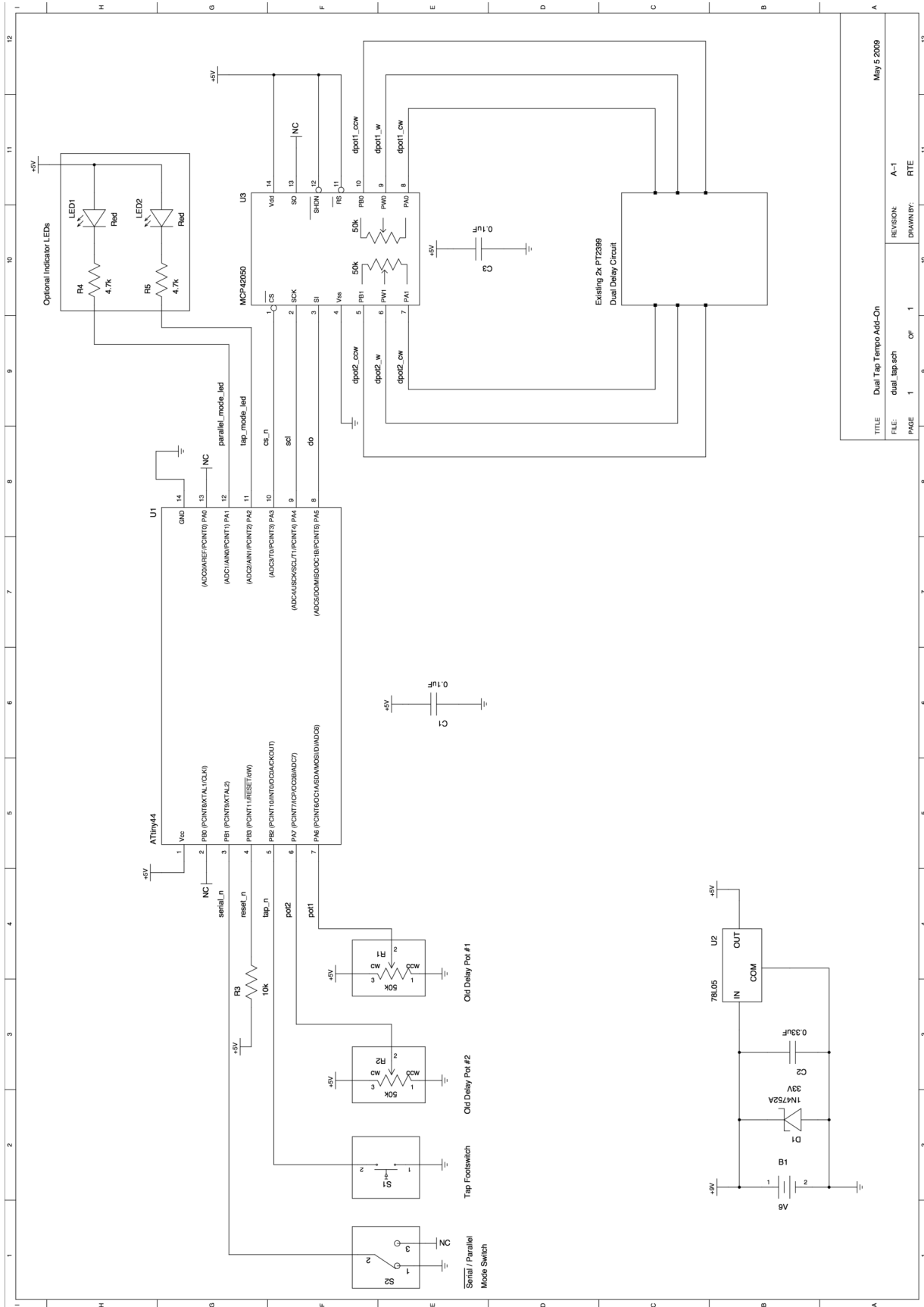

TITLE	Dual Tap Tempo Add-On	May 5 2009
FILE	dual_tap.sch	REVISON: A-1
PAGE	1 OF 1	DRAWN BY: RTE

Instructions for Use

Manual Mode

Upon power-up the MCU is in Manual Mode. The position of the analog pots are scanned and then sent directly to the digital pots.

Tap Mode

The first press of the tap button puts the MCU in to tap mode. The interval between the taps is timed and averaged over a sliding window to smooth out any human inaccuracies. The resulting tempo is stored in memory.

In Tap Mode the delay pots have new functions. As shown in the diagram one can select different beats based on the position of the knob:

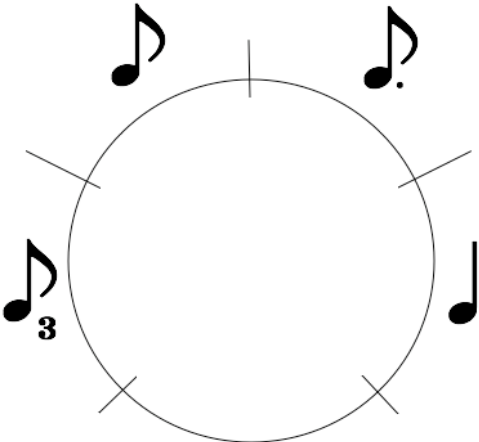

The beat selection is divided in to four sections. (Since the pot is analog there isn't a specific detent for each selection, just an area.)

Furthest CW	Quarter Notes	The delay is set to the same tempo as was tapped.
About 2 O'clock	Dotted Eighth Notes	The delay is set to 3/4 th of what was tapped.
About 10 O'clock	Eighth Notes	The delay is set to 1/2 of what was tapped.
Furthest CCW	Triplet Eighth Notes	The delay is set to 1/3 rd of what was tapped.

Other variations are possible by tapping the tempo at other than quarter notes. (Eg. Select Triplet Eighths and tap half notes for triplet quarter notes.)

When in Serial Mode pot #1 controls the beat and pot #2 is not used. In Parallel mode each pot controls the beat of their corresponding PT2399 chip.

To exit from Tap Mode and return to Manual Mode hold down the tap footswitch for 2 seconds.

LEDs

The “Parallel Mode” LED (LED1) will be off when the controller is in Serial Mode, and will be on when it is in Parallel Mode.

The “Tempo” LED (LED2) will be off when the controller is in Manual Mode, and will blink to the tempo when it is in Tempo Mode.

Calibration Mode

If the footswitch is held down during power-up the MCU will start in calibration mode. Here the delay time is set to mid scale (about 300ms). Pot #1 controls a fine offset. Left of 12 O'clock will speed up the delay (decrease in time), while right of 12 O'clock will slow it down (increase in time). The maximum offset available is +- 60ms.

To save the calibration offset to internal memory hold down the footswitch for 2 seconds. The MCU will store the value and continue with normal operation, applying the value to Tap Mode. (Manual mode will remain unaffected.) The calibration will be remembered even with the loss of power so the calibration should only have to be done once.